



HYCO 
WWW.HYCO.NET



The World's Leading Manufacturer of Hydraulic Cylinders

February 01, 2007



Hyco is the largest independent mobile hydraulic cylinder manufacturer in the world, serving the construction, material handling, waste handling, and agricultural equipment markets



Market Leadership	Customer Base	Manufacturing Excellence	Design Excellent	Experienced Management Team
<ul style="list-style-type: none"> ▪ 5-6% share of global mobile and industrial cylinder market with sales of about US\$200 million a year. ▪ Only independent manufacturer with facilities on three continents ▪ One-stop supply source for highly engineered cylinders 	<ul style="list-style-type: none"> ▪ Serves most of the largest multinational OEMs ▪ Relationships with top ten customers is 25 years on average ▪ Customers served from multiple Hyco locations ▪ Over 3,700 cylinders shipped daily worldwide. 	<ul style="list-style-type: none"> ▪ Six ISO 9001 certified facilities ▪ Other certifications include VDA 6.1 (QS 9000), ISO 14000 and ISO 9002 ▪ Quality certifications from most customers ▪ Reputation for superior technical characteristics and quality of its products 	<ul style="list-style-type: none"> ▪ Inter-plant design coordination. ▪ Group-wide state of the art CAD system ▪ Design consultant to major OEMs 	<ul style="list-style-type: none"> ▪ 20 years of experience on average ▪ Experienced plant managers focused on manufacturing improvements ▪ Key managers instrumental in developing Hyco's market leadership

Hyco is uniquely positioned in the market as the leading global mobile hydraulic cylinder manufacturer



- **Created by Centre Partners, a New York-based Investment Group, in mid-1998 with the acquisition of 4 Dana Cylinder Operations in Germany, Canada, the USA.**
- **Expanded 2000/2001 with the acquisition of plants in Germany, Canada and Brazil, and the development of new plants in the US and Canada.**
- **Today, Hyco is the largest independent supplier of Hydraulic Cylinders to the Mobile Equipment Market and continues to add customers and capabilities.**

Mission



Hyco's Corporate Mission is to be the preferred worldwide supplier of mobile hydraulic cylinders.

Hyco will pursue this mission through development of long-term partnerships with Employees, Suppliers and Customers and by offering its Partners three important features which help confirm Hyco as the Industry Leader:-

Seamless Global Supply:

For decades, Hyco has routinely managed the design, manufacture and logistics of multiple, global customer locations, using its multilingual capabilities, multiple locations and electronic data transfer capabilities.

One-Stop-Shopping:

Hyco offers a full line of hydraulic cylinders and related products for Mining, Construction, Agricultural, Waste Handling and Material Handling applications. Hyco designs and produces single-stage hydraulic cylinders, telescopic cylinders (single- and double-acting), hydro-pneumatic suspensions and piston accumulators. Hyco's extensive Engineering capabilities help OEM customers to keep their supply base lean and effective.

Lowest Delivered Costs:

Hyco uses its international operations to monitor options for material costs, labor costs, capacity constraints and currency movements. Hyco believes that central design control and local manufacture offer important cost control opportunities.

Geographic Locations



Hyco's facilities are strategically located in close proximity to its OEM customers, allowing the Company to leverage regional variances in production costs to obtain the lowest delivered cost for its customers

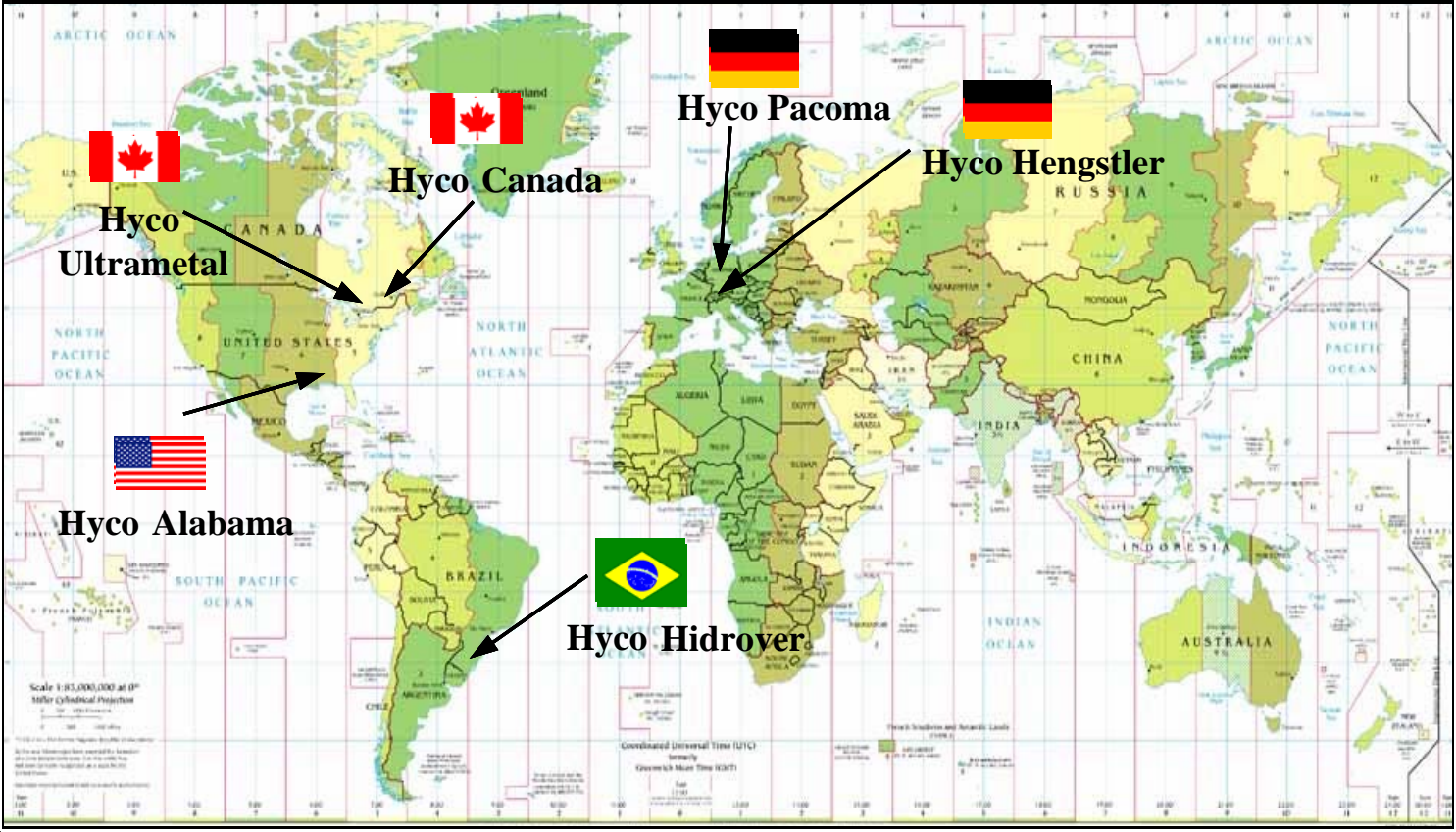

Sales Breakdown



Hycos is a highly diverse business focused on four major end markets and three continents with Global sales in excess of US\$200 million.

- Hycos's markets require highly-engineered cylinders
- Hycos's market's are cover a wide range of products and applications
- Hycos's markets cover 3 continents

2006 Revenue by End Market

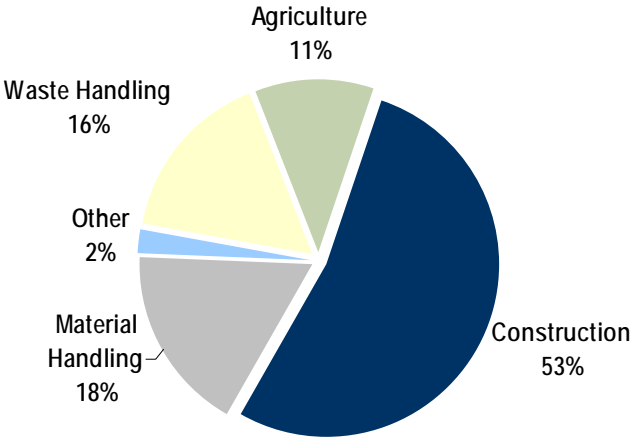

2006 Revenue by Geographic Region

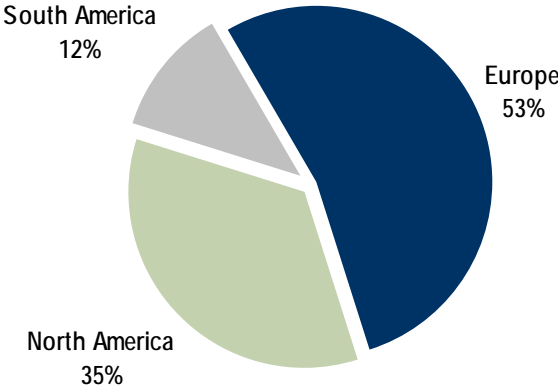

Organizational Structure



Hyco is led by one of the most experienced management teams in the industry

- Average tenure of the top thirteen professionals is over 10 years
- Core management has worked together for over twelve years
- Six plant managers in total possess over 150 years of hydraulics industry experience

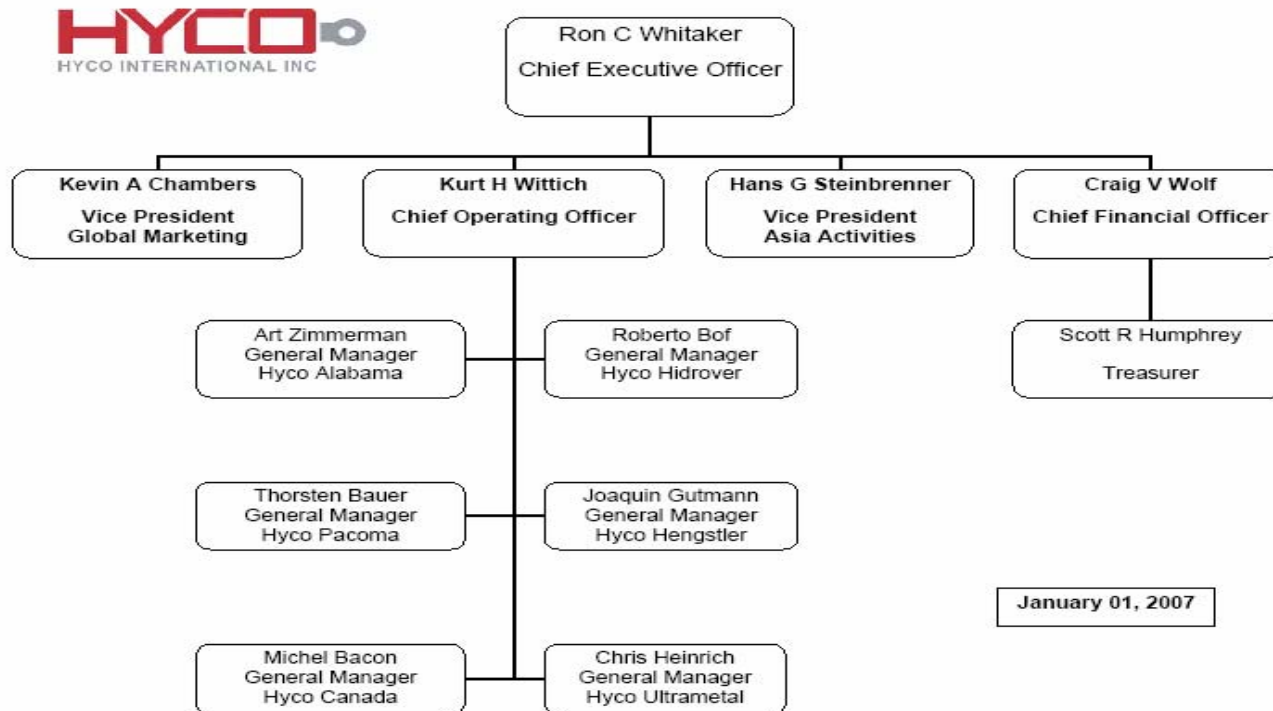

Customer Overview



Hyco has deep, long-standing relationships with the largest, multinational OEMs in the construction, material handling, waste handling, and agricultural equipment markets. Hyco's Top 10 Customers include the following in no particular order, none of which account for more than 16% of total revenue:-

Major Customers





Hyco produces a complete range of rod and telescopic cylinders for mobile applications in six international locations.

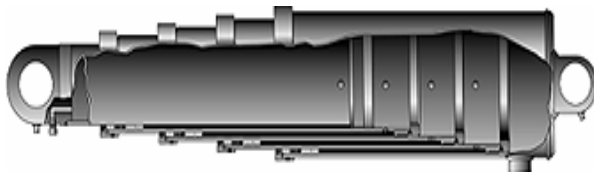
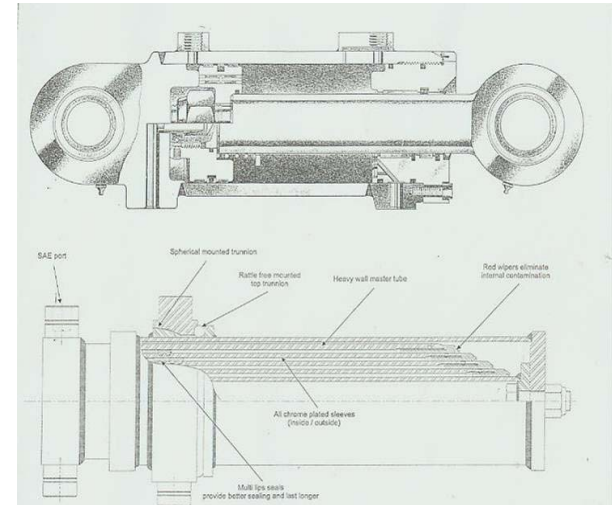

Hyco Plants



Hyco Hengstler, Germany



Hyco Pacoma, Germany



Hyco Hidrover, Brazil



Hyco Canada, Canada



Hyco Ultrametal, Canada



Hyco Alabama, USA

Hyco International Inc



Hyco Alabama specializes in producing telescopic cylinders for waste handling equipment and rod cylinders for construction and agricultural applications

Product Applications



Garbage and Dump Trucks



Street Cleaners



Agricultural & Construction Equipment

End Markets Served

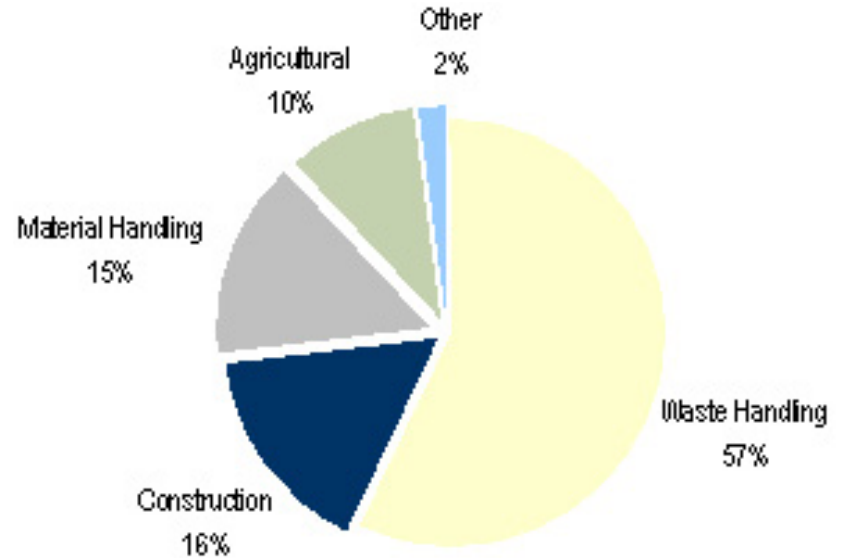

Product Focus

- Averaging 380 cylinders shipped a day of both Solid Rod and Telescopic, Single and Double Acting.
- Bore size: 2" and up
- Stroke size: from less than 10" to greater than 240"

Key Manufacturing Processes

- Tube and rod machining
- Inertia welding
- Chrome plating
- OD Grinding
- Skiving and roller burnishing

North American Operations

Hyco Canada Product Overview



Hyco Canada manufactures both rod and telescopic cylinders in various sizes for a number of applications

Product Applications



Forestry Equipment



Waste Handling



Cranes



Aerial Lifts



Oil Field

End Markets Served

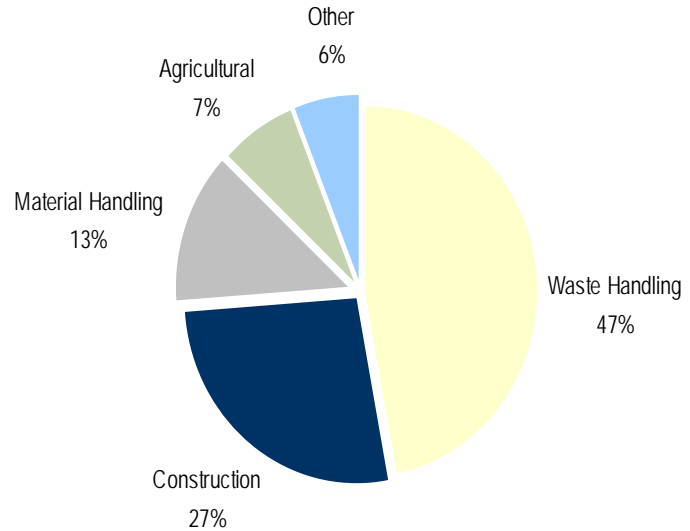

Product Focus

- Large cylinders used for heavy construction, waste handling and lifting applications.
- Rod and Telescopic cylinders, Single & Double Acting with a total average output of 160 a day.
- Bore size: 4 – 18", Strokes from 6" to 240".

Key Manufacturing Processes

- Tube and rod machining
- Subarc welding
- OD Grinding
- Robotic welding
- Skiving and roller burnishing

North American Operations

Hyco Ultrametal Product Overview



Hyco Ultrametal has over 35 customers with a focus on light construction, forestry and material handling equipment

Product Applications

End Markets Served



Construction Equipment



Mining



Material Handling



Forestry

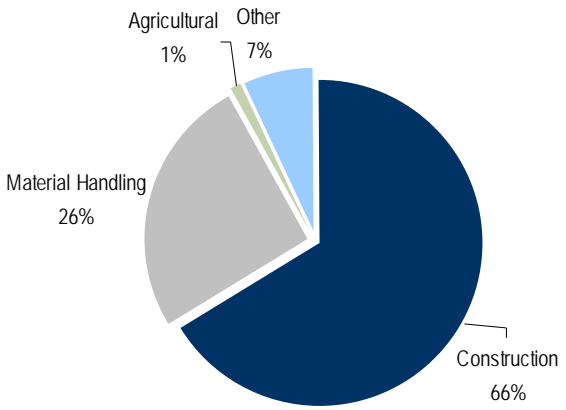

Product Focus

Key Manufacturing Processes

- Daily output in excess of 320 consisting mainly of Double Acting cylinders with high duty cycles
- Expertise in manufacturing cylinders used in medium construction applications
- Bore sizes of 2" and up and Strokes from 3" to over 80"

- Tube and rod machining
- Component machining
- Robotic welding
- Skiving and roller burnishing

European Operations

Hyco Pacoma Product Overview



Hyco Pacoma offers a broad array of products and processes used in construction, material handling and agricultural applications

Product Applications

End Markets Served



Cranes



Construction Equipment



Material Handling Equipment



Automotive Lifts

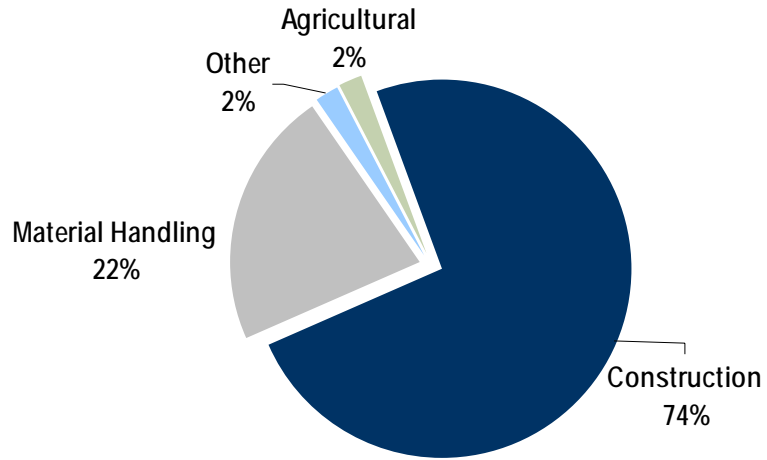

Product Focus

Key Manufacturing Processes

- High specification rod cylinders which demand intensive design input, high quality and high volume production in excess of 2,000 units a day.
- Expertise in cylinders for agricultural and light to heavy construction equipment applications.
- Bore sizes 2" and up and Strokes from 6" to over 360".

- Tube and rod machining
- Friction/inertia welding
- Chrome plating
- Paint line
- Component machining
- OD grinding

European Operations

Hyco Hengstler Product Overview



Approximately 72% of Hyco Hengstler's revenue was generated from sales to the construction equipment market

Product Applications



All Terrain Cranes



Tracked and Wheeled Excavators



Wheel Loaders



Construction

Product Characteristics

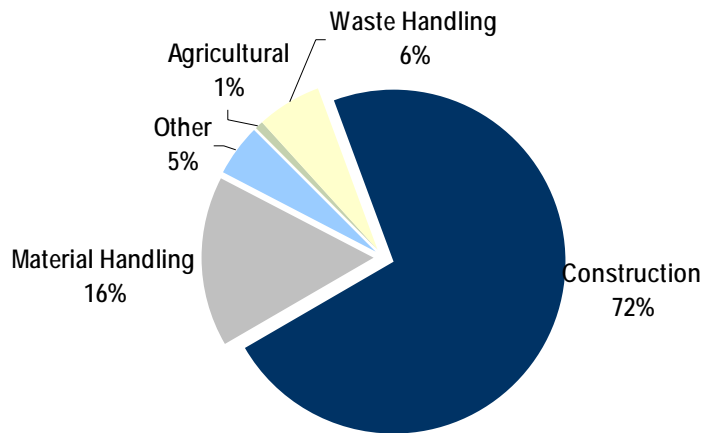

Product Focus

- Excavators, mobile cranes, refuse trucks, construction equipment
- Bore from less than 2" and up, with Strokes from 10" to over 60".
- Daily output averages 80 cylinders

Key Manufacturing Processes

- Tube and rod machining
- Friction/inertia welding
- Paint line
- Skiving and roller burnishing

Brazilian Operations

Hycó Hidrover Product Overview



Hycó Hidrover traditionally focused on serving the South American agricultural equipment market, but is now moving rapidly in to construction equipment.

Product Applications



Agricultural Equipment



Construction Equipment



Waste Handling Equipment



Material Handling Equipment

Product Focus

- Single and double acting rod cylinders
- Expertise in producing cylinders for agricultural and light construction applications
- Expertise in high-spec sub-sea cylinders for oil well applications.
- Daily average output exceeds 760 cylinders

Key Manufacturing Processes

- Tube and rod machining
- Friction/inertia welding
- Component machining
- Finish paint

Hyco Plant Capabilities



Plant Capability Matrix - February 2006

	By Product					By Bore Size		
	Telescopics	Ag and Light Construction	Medium Construction	Heavy Construction	Material Handling	Under 4" (15mm)	4-6" (100-150mm)	Over 6" (150mm)
	Dump Truck Roll-offs Refuse Trucks Oil Field	Tillage Sprayers SSL MiniEx	BHL WL Dozers Graders	Cranes Concrete Pump Excavators Oil Field	Forklifts Carlifts Manlifts			
Alabama	Expertise	Produce			Produce	Expertise	Expertise	Expertise
Canada	Expertise	Produce	Produce	Expertise		Produce	Expertise	Expertise
Hengstler			Produce	Expertise		Expertise	Expertise	Expertise
Hidrover		Expertise	Produce			Expertise	Expertise	
Pacoma		Expertise	Expertise	Expertise	Expertise	Expertise	Expertise	Produce
Ultrametel		Produce	Expertise		Expertise	Expertise	Expertise	

	By Process					By Stroke		
	Skive	Friction/Inertia Welding	O.D.Grinding	Chrome Plating	Finish Paint	Under 10" (250mm)	10-60" (250-1500)	Over 60" 1500mm
Alabama	Expertise	Expertise	Expertise	Expertise		Expertise	Expertise	Expertise
Canada	Expertise		Expertise		Produce		Expertise	Expertise
Hengstler	Expertise	Expertise			Expertise		Expertise	Expertise
Hidrover	Expertise	Expertise			Expertise	Expertise	Expertise	Produce
Pacoma	Expertise	Expertise	Expertise	Expertise	Expertise		Expertise	Expertise
Ultrametel	Expertise				Produce	Produce	Expertise	Produce

Key	Expertise	Can and does produce and is good at it. Has appropriate equipment
	Produce	Produces, but has no special expertise, abilities or equipment.

Summary



Hyco has more than 20 year's experience as a supplier to major manufacturers of Excavators, Wheeled Loaders, Backhoes, Skid Steers, Telehandlers, Forestry Equipment and other Construction, Agricultural, Mining and Utility Equipment.

- **Hyco has considerable multi-national experience with both local manufacturing as well as international supply chains.**
- **Hyco has the design and manufacturing technology to support most customers supply needs.**
- **Hyco continues to develop its facilities to match its partners market requirements.**
- **Hyco's distribution network in Central and North America supports an important standard cylinder market.**
- **Hyco is its industry leader in design innovation, quality and service.**